

# FLTX20H

## Datasheet

# FULBAT<sup>®</sup>

## MOTORCYCLE BATTERY



**LiFePO<sub>4</sub>**  
**NON-SPILLABLE**



The new Lithium range is designed to offer the ultimate riding experience.

Ready to use and with ultra-light weight conception, this LiFePO<sub>4</sub> range will ensure extreme starting performance, very low self-discharge and extreme cycle life. Thanks to the Battery Management System integrated, these batteries offer a very safe solution, ideal for the most demanding riders.

### FEATURES

- Ready to use & Maintenance Free
- Ultra lightweight compare to lead acid battery
- Very high cold cranking performance
- Ultra safe thanks to the integrated BMS
- Very fast recharge
- Multi-positional fitment
- Integrated LCD battery tester
- Very low self-discharge

### BATTERY REPLACEMENT

- FTX20-BS

### TERMINAL

Front



Side



Top



3D



### SPECIFICATIONS

Voltage	Capacity	CCA (EN)
<b>12.8V</b>	<b>12.0Ah</b>	<b>720A</b>
Energy	Charging current std.	Charging current max
<b>153.6Wh</b>	<b>6.0A</b>	<b>12.0A</b>

#### BMS FUNCTION:

- Over discharge protection
- Over charge protection
- Cell equalization

### DIMENSIONS & WEIGHT

Length	175±2mm
Width	87±2mm
Total Height	155±2mm
Gross weight	1.12kg

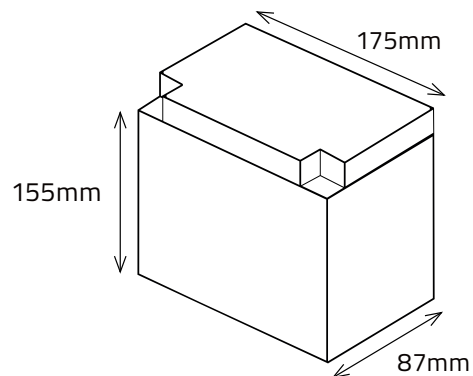

### POLARITY

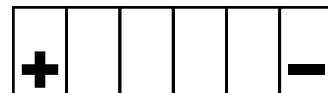

### MOUNTING ANGLES

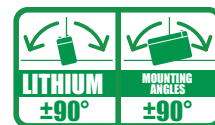

### APPLICATIONS



Motorcycle



Scooter



ATV



SSV & UTV



Snowmobile



Watercraft