

FLT12B/14B

Datasheet



LiFePO₄
NON-SPILLABLE



The new Lithium range is designed to offer the ultimate riding experience.

Ready to use and with ultra-light weight conception, this LiFePO₄ range will ensure extreme starting performance, very low self-discharge and extreme cycle life. Thanks to the Battery Management System integrated, these batteries offer a very safe solution, ideal for the most demanding riders.

FEATURES

- Ready to use & Maintenance Free
- Ultra lightweight compare to lead acid battery
- Very high cold cranking performance
- Ultra safe thanks to the integrated BMS
- Very fast recharge
- Multi-positional fitment
- Integrated LCD battery tester
- Very low self-discharge

BATTERY REPLACEMENT

- FT12B-4
- FT12B-BS
- FT14B-4
- FT14B-BS

TERMINAL

Front



Side



Top



3D



SPECIFICATIONS

Voltage	Capacity	CCA (EN)
12.8V	6.0Ah	360A
Energy	Charging current std.	Charging current max
76.8Wh	3.0A	6.0A

BMS FUNCTION:

- Over discharge protection
- Over charge protection
- Cell equalization

DIMENSIONS & WEIGHT

Length	150±2mm
Width	69±2mm
Total Height	130±2mm
Gross weight	1.10kg

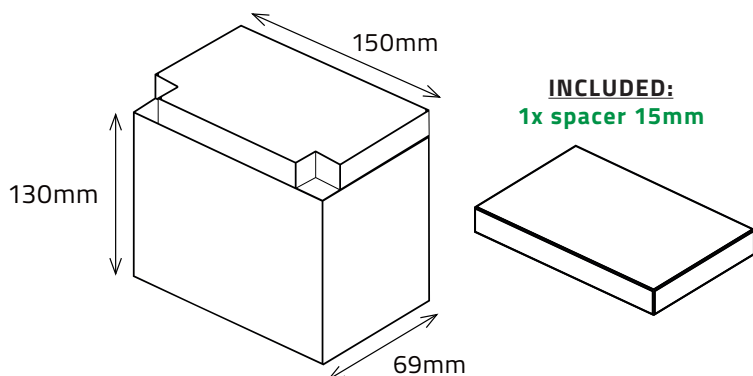

POLARITY



MOUNTING ANGLES



APPLICATIONS



Motorcycle



Scooter



ATV



SSV & UTV



Snowmobile



Watercraft